

" THIS ARTICLE IS INTENDED FOR YOUR REFERENCE ONLY.

ACTUAL PARTS, YEARS AND BODY STYLES CONTAINED

IN THIS ARTICLE MAY DIFFER SLIGHTLY FROM YOUR APPLICATION. "

YOU CAN DO IT EASY UPGRADES

1955-57 LED TAILLAMP UPGRADE



Those of us who own an early Chevy know how small the taillamps are—and how difficult they can be to see; day or night! The 1955 tail and brake lamps tend to be very dim, 1956's are tiny, and 1957's are very low and fairly small. One of the easiest, quickest and least expensive upgrades you can make is the addition of LED rear brake/tail/turn signals. Our kits are complete, easy to install and are completely invisible when installed, so they may be used on original restored cars as well as customs. Our installation will cover the 1955 Premium Kit #28-39 along with the 1955 #28-40 back-up and amber signal add-on. Installation for 1956-57 cars is very similar.

Parts Needed:

- 28-38 1955 LED Kit
- 28-39 1955 LED Premium Kit (Includes internal side marker light)
- 28-40 1955 LED Add-On For Back-Up Lamps & Amber Turn Signals
- 28-41 1956 LED Kit
- 28-37 1957 LED Kit
- 128002 1955-66 Stepside Pickup LED Kit

Tools Needed:

- Phillips screwdriver
- Pliers
- Wire Cutters

Time Frame:

1 Hour

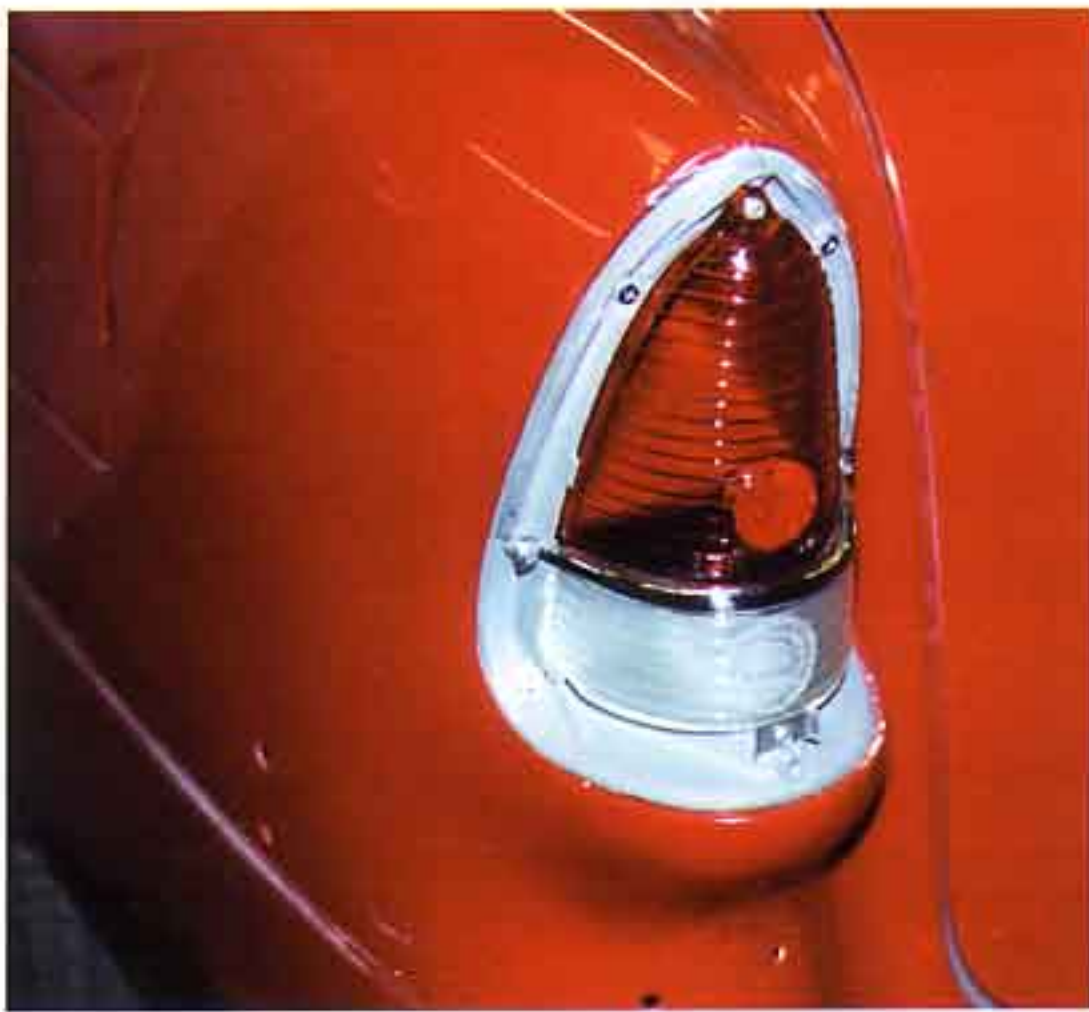

Photo #1a & 1b: Remove the original taillamp bezels and lenses. Remove the stock taillamp wiring from the housing by twisting the rubber boot and pigtail assembly turn counter-clockwise.



Photo #2a & 2b: Using your wire cutters, cut the two taillamp wires on each side of the car as close to the plastic connector as possible. Feed the wires back through the taillamp bulb hole in the housing. Using the scotch-lock type connectors provided with the kit, connect the black wire in the original harness to the black wire in the LED harness and connect the corresponding colored wires.

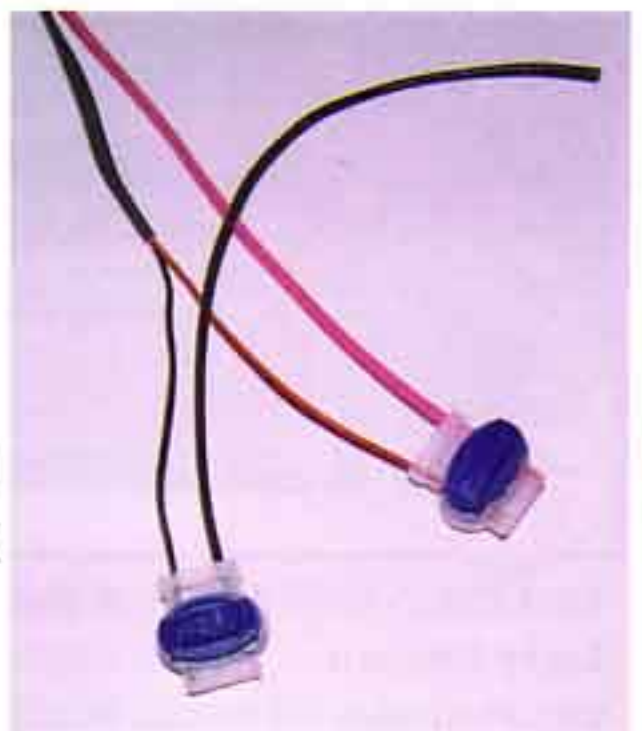
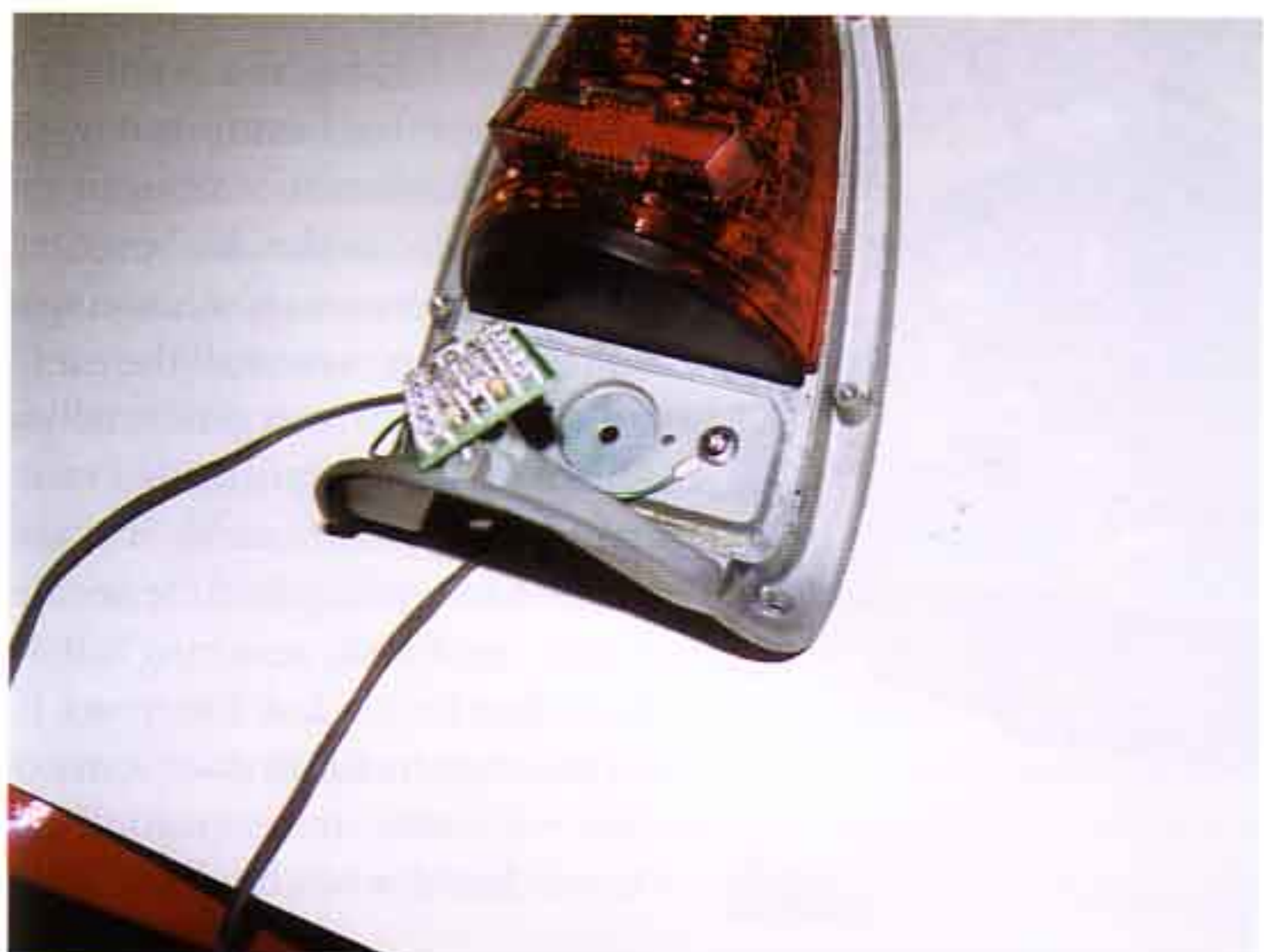
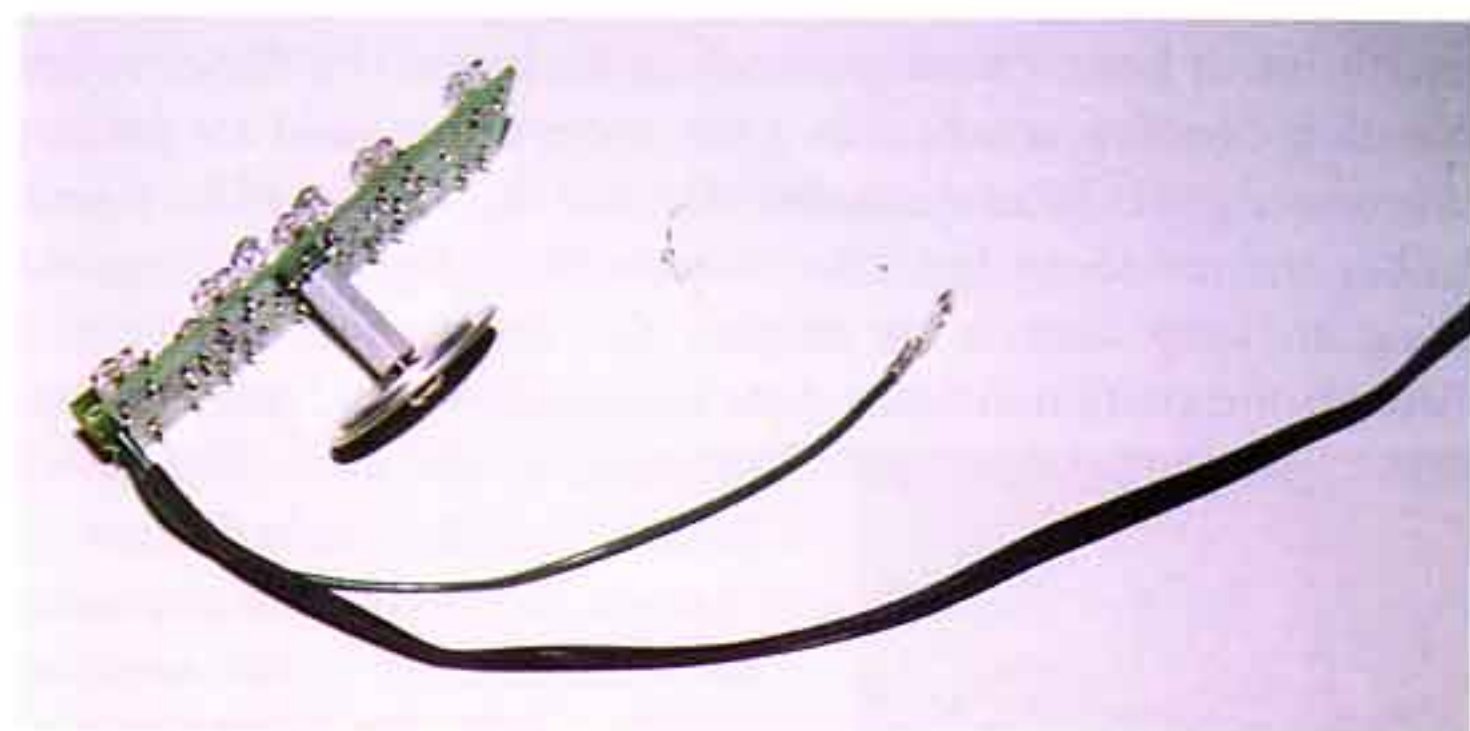
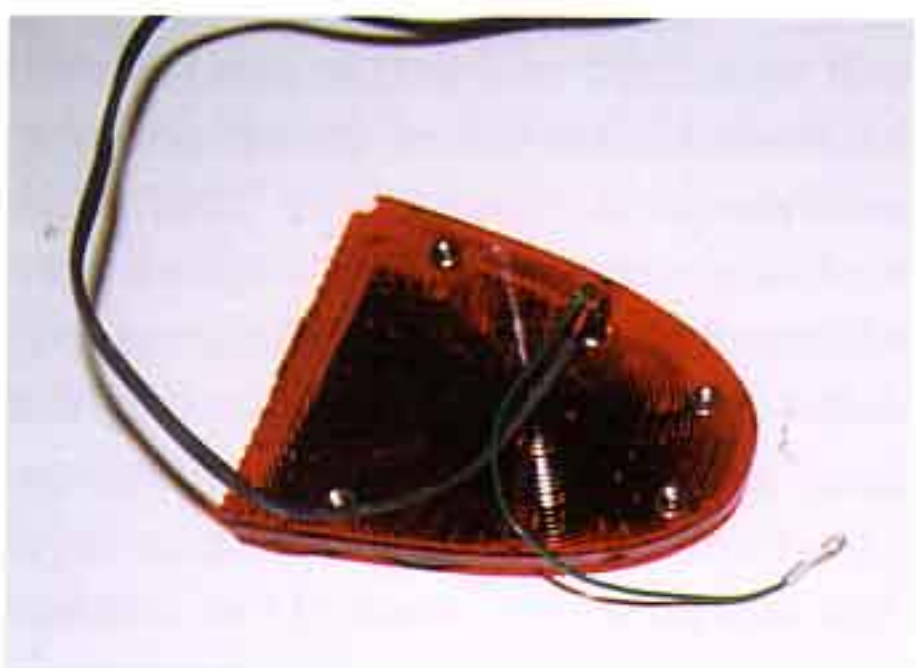



Photo #3a & 3b: The 1955 kits include a new inner lens to which the new LED components are mounted. The 1956-57 kits include a PC board that easily installs under the taillamp lenses. Install the lens, trapping the green ground wire under one of the mounting screws.



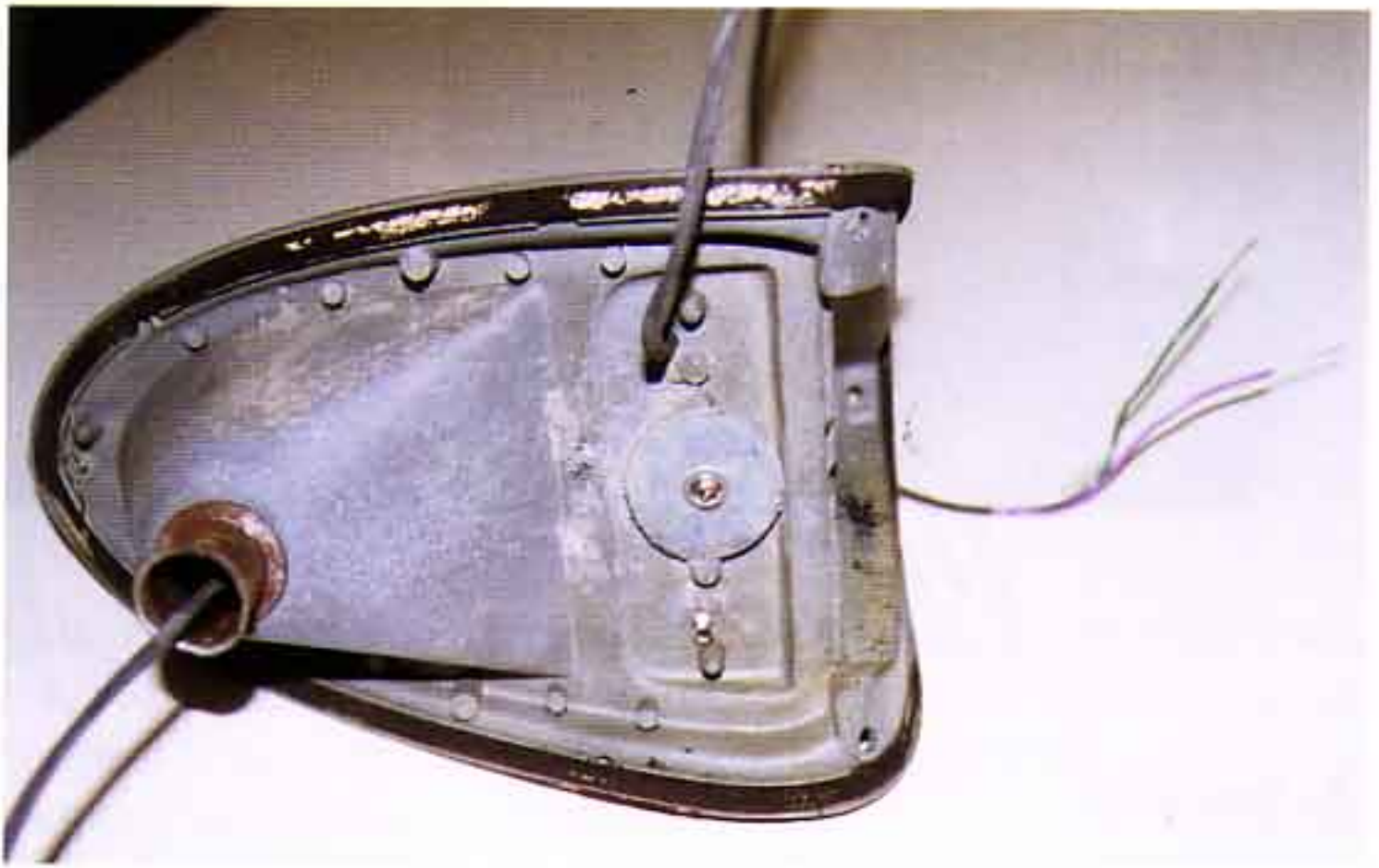

Photo #4a, 4b & 4c: For 1955 owners, the amber turn signal and super-bright back-up lamp add-on is available as part #28-40. This kit installs in the large lower hole in the taillamp housing. The large mounting washer fits on the body side of the housing and the smaller washer fits on the lens side. Two additional holes will need to be drilled in the housing adjacent to the LED mount hole; one for the wiring harness to pass through, one to attach the green ground wire to.

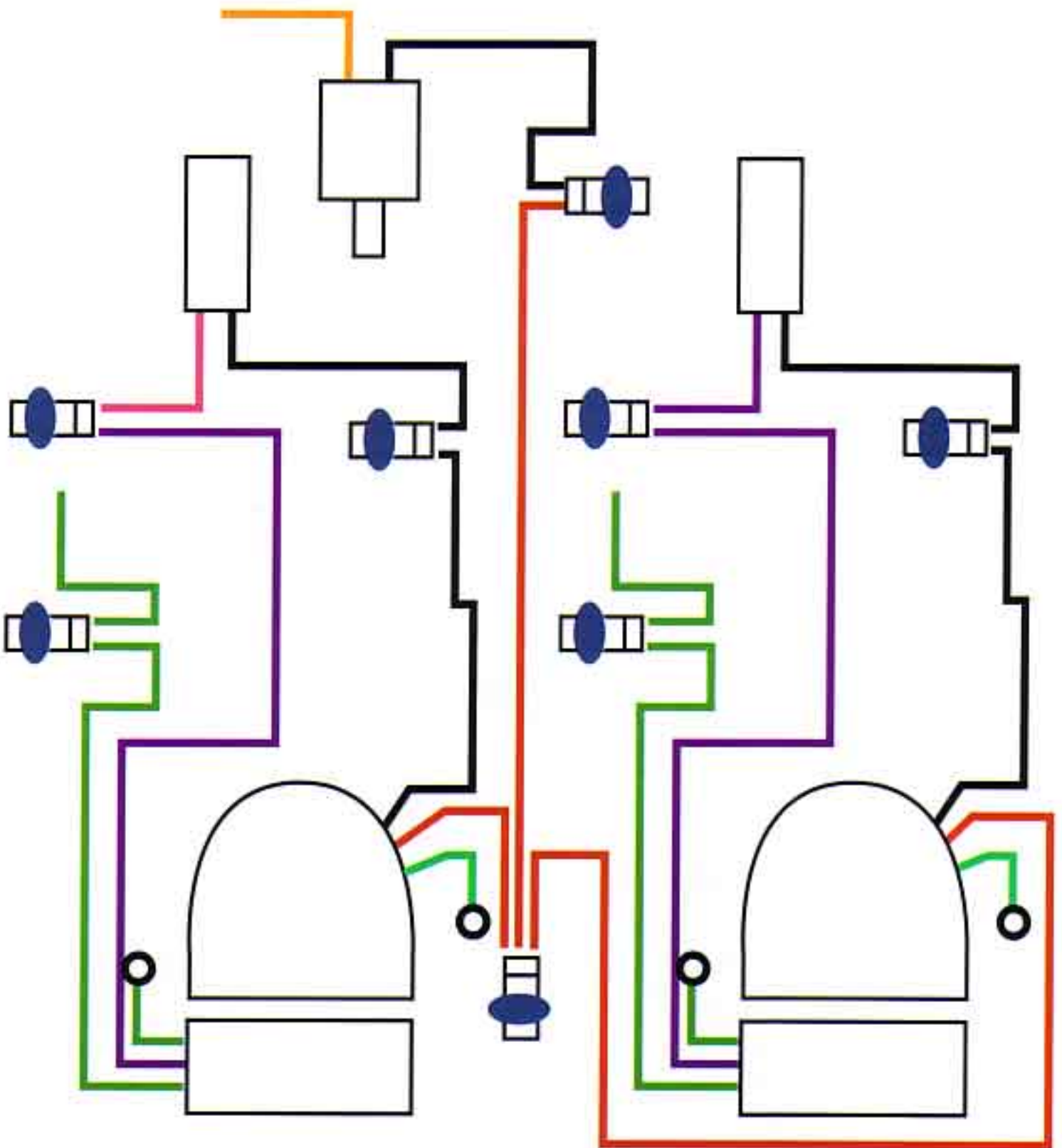

Diagram #5: Complete the additional turn signal and back-up lamp wiring following the wiring diagram above.

Reassemble the lenses and bezels and test all functions. You will immediately notice how much brighter your taillamps, brake lamps and turn signals are now! Enjoy! 